

## High pressure metering and dispensing at an affordable cost.



Linden's entry level machine, the ECO Rim, is an economical option that can be used in applications that don't require high volume production runs or stringent chemical processing demands. This standard design features a simple layout and economical components modeled after Hi-Tech and SB Machines. Whether you are looking to foam polyurethane floor mats or insulating coolers, this entry level machine might be a good alternative for your processing needs.

### Standard Features

- 30-gallon (110 liter) day tanks (Non-ASME rated)
- Tank level indication with site tube
- RHL axial piston metering pumps
- Magnetic coupled Iso metering pump
- Tube and shell heat exchangers
- Allen Bradley PLC with and HMI

### Optional Features

- L-type mix head
- 80-gallon (300 liter) day tanks (Non-ASME rated)
- Tank autofill control from drums or totes
- Mix head boom, machine mounted, 10 feet reach
- Magnetic coupled Polyol metering pump
- Fixed speed electrical agitators
- Closed loop flow control
- Temperature control unit
- Air dryer

### Footprint

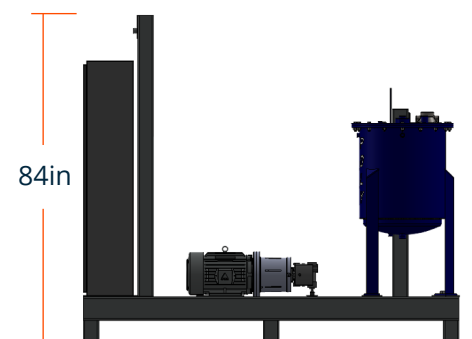
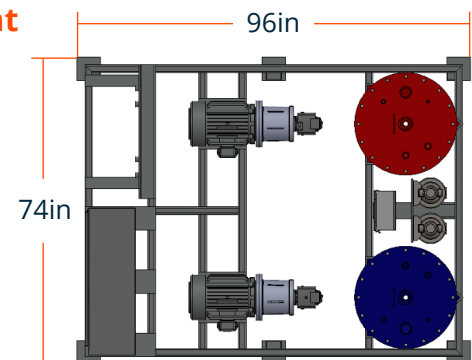

Machine Size	ER11	ER33
Output ranges @ 1:1 ratio		
g/sec	75 - 636.8	365 - 1827
Kg/min	7.6 - 38.2	21.9 - 109.6
#/min	16.8 - 84.2	48.3 - 241.7